



INSTALLATION INSTRUCTIONS

www.vikingbags.com

888-208-1949 |

support@vikingbags.com

VIKINGBAGS CLASSIC MOTORCYCLE TAIL BAG INSTRUCTION

Parts List

1. Sissy Bar Bag
2. Top Roll Bag
3. Backpack Straps
4. Shoulder Straps
5. Rain Cover
6. Mounting Straps
7. Extensions Straps
8. Installation Instructions

Step 1

1-Refer to diagram (Fig B.) use the included rods to adjust the width of the sissy bar yoke to fit snugly around your bike's sissy bar pad. The rods can be inserted to make the yoke narrow or wide to fit sissy bar tightly. You can also insert the rods at an angle if your sissy bar pad is not rectangular.

2-Ensure that the rods are fully inserted, through the top loop securely into the bottom loop. Once in place, tighten the Velcro flap which covers the top loop.



Fig.A

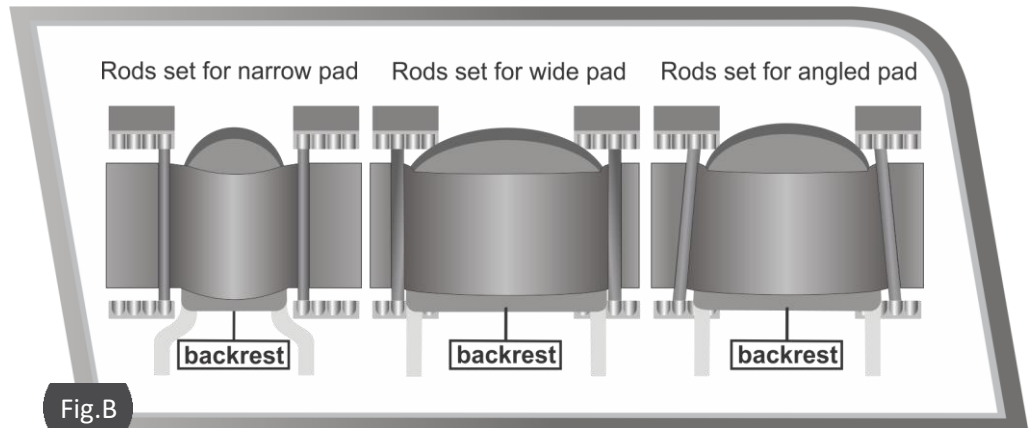

Fig.B

Step 2

Each bag also has two quick-release nylon straps, located on either side of the bag. These straps must be wrapped around the uprights (saddlebags support, turn signal upright, frame rail etc.) and the attached to the corresponding buckles on each side. Ensure that the straps are tightened such that the bags are securely held in one place.

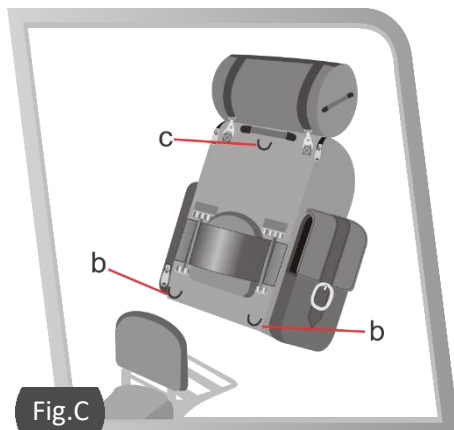

Fig.C

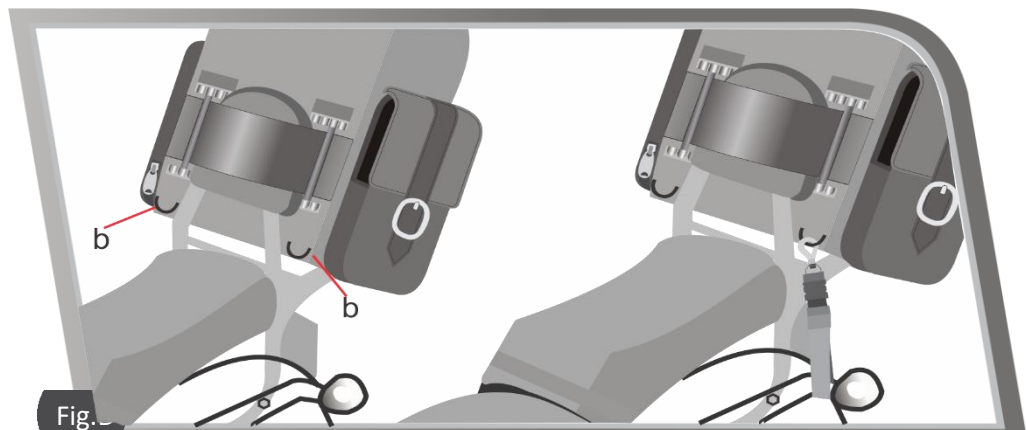

Fig.D



INSTALLATION INSTRUCTIONS

www.vikingbags.com



888-208-1949 |



support@vikingbags.com

Step 3

Backpack straps are included in order for the rider to carry the sissy bar bag easily. The straps connect to (c) and (b) as shown in Fig (C)

Step 4

Shoulder Straps is included to carry the roll bag easily.

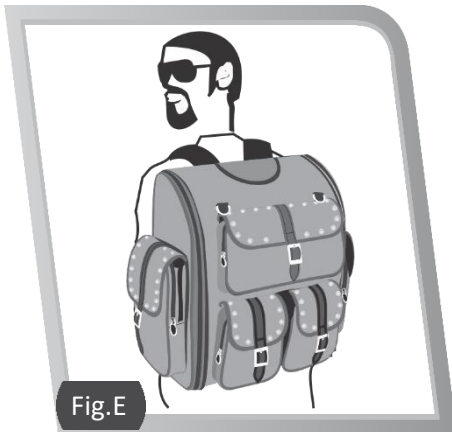

Fig.E



Fig.F

Warning

READ ALL INSTRUCTION THOROUGHLY BEFORE STARTING!

You are responsible for correct installation and safe use of this bags. Seek qualified instruction If you are uncertain about its capabilities and limitations or is you need help with installation. Use of the bag in a manner other than its intended purpose or contradictory to the warning and instruction provide could cause loss of control of your motorcycle, possibly resulting in personal injury or death.

- Do not use this bag if any part of the motorcycle system has deteriorated, loosened or is beginning to fail. If you have doubts as to the security of bag's installation, stop using it.
- After every stop check the to be certain that it did not shift while riding and verify that the straps will not contact or interfere with any part of the drivetrain, suspensions, breaks or wheels.
- Do not exceed 15 pounds' total weight of bag, contents and attachments or the load limits of the motorcycle as specified in the owner's manual supplies with the bike or from the bike manufacture.
- When the bag id removed. All loose straps must be removed from the motorcycle, or secured, so that they do not contact or interfere with any part of the drivetrain, suspension, brakes or wheel before operating the motorcycle.
- Always remove or stow all shoulder and backpack straps before attaching bag to motorcycle.